

EPOXY-COATED DUCTILE IRON GLOBE VALVE RISING STEM

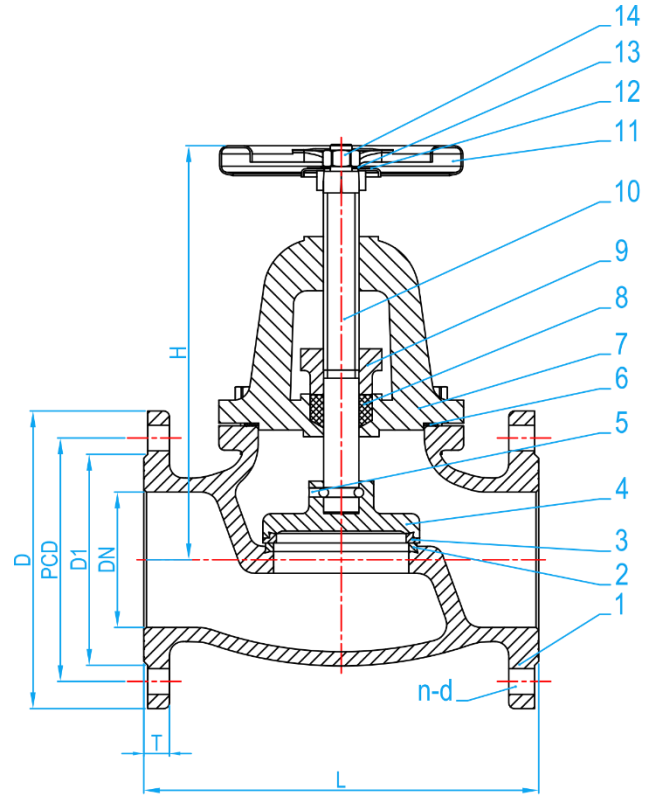

COMPLY WITH BS EN 13789: 2010
BS EN 1092-2:1997



CROSS SECTIONAL VIEW

COMPONENT PARTS

ITEM	PARTS	MATERIAL
1	Body	Epoxy-coated Ductile Iron
2	Valve Body Sealing	DZR Brass
3	Gate Sealing	DZR Brass
4	Disk	Epoxy-coated Ductile Iron
5	Screw	AISI304
6	Gasket	EPDM
7	Bonnet	Epoxy-coated Ductile Iron
8	Packing Ring	Flexible Graphite
9	Gland Packing	Epoxy-coated Ductile Iron
10	Stem	AISI304
11	Handle	Cast Iron
12	Signs	Aluminum
13	Washer	AISI304
14	Nut	AISI304

STANDARD SPECIFICATIONS

Nominal Pressure	1.6 Mpa
Working Medium	Water
Working Temperature	0°~85°C

DIMENSIONS

SKU	DN (mm)	D1 (mm)	PCD (mm)	D (mm)	n-d (mm)	T (mm)	L (mm)	H (mm)	WEIGHT (kg)	PALLET (NOS)
GLVDIN100	100	156	180	220	8-19	19	292	310~350	27.07	30